

NOTES:

1. FOR GRAVITY APPLICATIONS ONLY.
2. ALL PROCEPTOR® UNITS ARE MANUFACTURED WITH FIBERGLASS REINFORCED PLASTICS. PHYSICAL CHARACTERISTICS AND THICKNESS: POLYESTER RESIN AND E GLASS MINIMUM THICKNESS 1/4" WALL AND 3/8" TOP AND BOTTOM BOWLS.
3. ALL PROCEPTOR® UNITS ARE TO BE INSTALLED IN ACCORDANCE WITH THE MANUFACTURERS INSTALLATION INSTRUCTION.
4. STANDARD PIPE STUBS ARE SOCKET SDR 35 PVC SEWER MATERIAL (SCHEDULE 40 ADAPTORS ADDED FOR ALL PROJECTS IN USA).
5. GMC/OMC/SMC 50 - 300 UNITS COME STANDARD WITH 4" INLET AND OUTLET (OTHER CUSTOM SIZES AVAILABLE AT EXTRA CHARGE).
6. EXTENSION COLLAR TO BE ORDERED TO MEET FINISHED GRADE, CUT ON SITE FOR FINAL ADJUSTMENT AND CAULKED WITH SIKAFLEX BY CONTRACTOR FOR WATERTIGHT SEAL.
7. COVERS AVAILABLE FOR H20 TRAFFIC LOADING, PEDESTRIAN LOADING OR ABOVE GROUND INSTALLATION.
8. CONSULT GREEN TURTLE™ FOR OTHER SIZES.
9. 30 YEAR WARRANTY AGAINST LEAKS, AND STRUCTURAL FAILURE.
10. U.S. PATENT #5,746,912; CDN PATENT #2,195,822

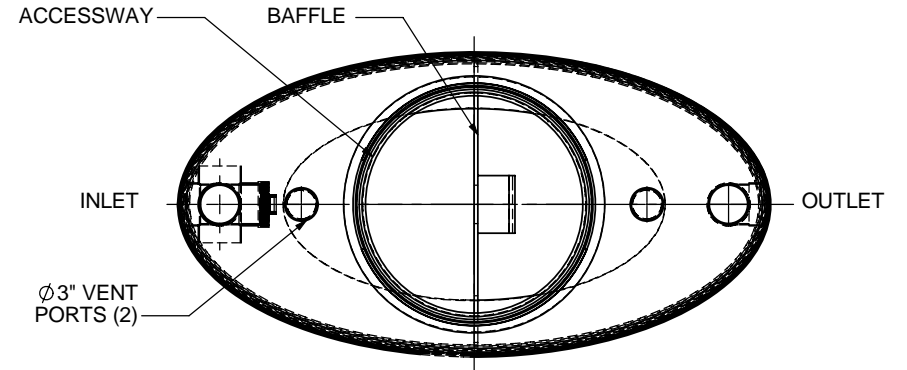

TOP VIEW

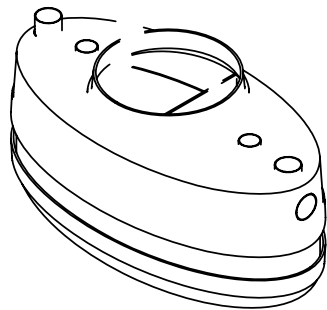

ISOMETRIC VIEW

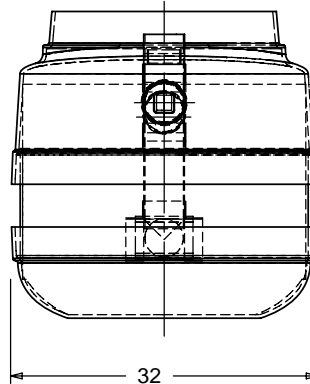

SIDE VIEW

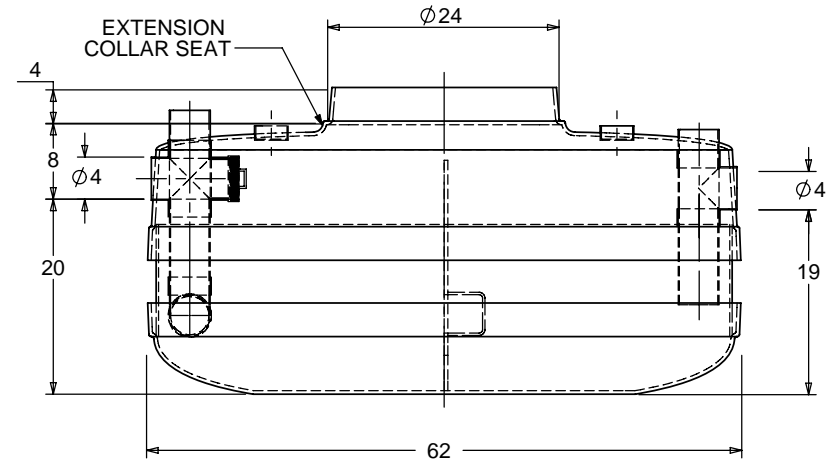

FRONT VIEW

TOTAL WET VOLUME: 100 GAL
 MAX. GREASE CAPACITY: 42 GAL
 MAX SOLIDS CAPACITY: 23 GAL

CONSULT LOCAL AUTHORITIES FOR MINIMUM SIZE OF SEPARATORS

TITLE: PROCEPTOR® F.O.G. SEPARATOR		REV	DATE	DRAWN
GMC 100 GALLON INTERCEPTOR		1		
4" INLET & OUTLET		2		
24" ACCESSWAY		3		
ALL DIMENSIONS IN INCHES.		4	OCTOBER 27, 2006	L. SIMKINS
PROJECT: WO:		5	DEC. 13, 2006	L. SIMKINS
		6	NOV. 25, 2008	L. SIMKINS
		7	NOVEMBER 3, 2009	L. SIMKINS
		8		
✓ OPTIONS:		9		
GREASE SENSOR ALARM		10		
SUCTION PIPE FOR INDOOR INSTALLATION				
ABOVE GROUND INSTALLATION				
		DRAWN BY: F CHANDLER		
		DRAWN DATE 9/2/04		

Proceptor®
 by greenturtle®
 US 877 428 8187 CAN 877 966 9444
 www.greenturtletech.com

SIZE	DWG. NO.	REV.
A	GMC 100	7
SCALE:1:20	DO NOT SCALE DRAWING	SHEET 1 OF 1